

# FP1150 Fiber Connection Module

FPMA0922



The 1U rack-mount enclosure is used to house the dual end modules for the FP1150 and enables the splicing of field cable to patch cords (for connection to the FP1150 processor). The module is designed for installation in a 19-inch rack. The slide-out tray provides easy access to the optical module to facilitate field splicing.

### Specifications

- Swing out panel tray with thumbnail screw latch
- Designed for mounting in 19-inch rack
- Dimensions:
  - Width: 43 cm (17 in)
  - Height: 1U
  - Depth: 30 cm (11 in)
- Capacity: 2 splice trays
- Patch Cord Connector: FC/APC (x2)
- Patch Cord Length: 2 meters (78 in)
- Weight: 5.4 kg (12 lbs)
- Material: 16 GA powder-coated steel, black
- Includes dual end module in a sealed splice tray
- Fiber splices made in user-accessible splice tray (12 splice capacity)

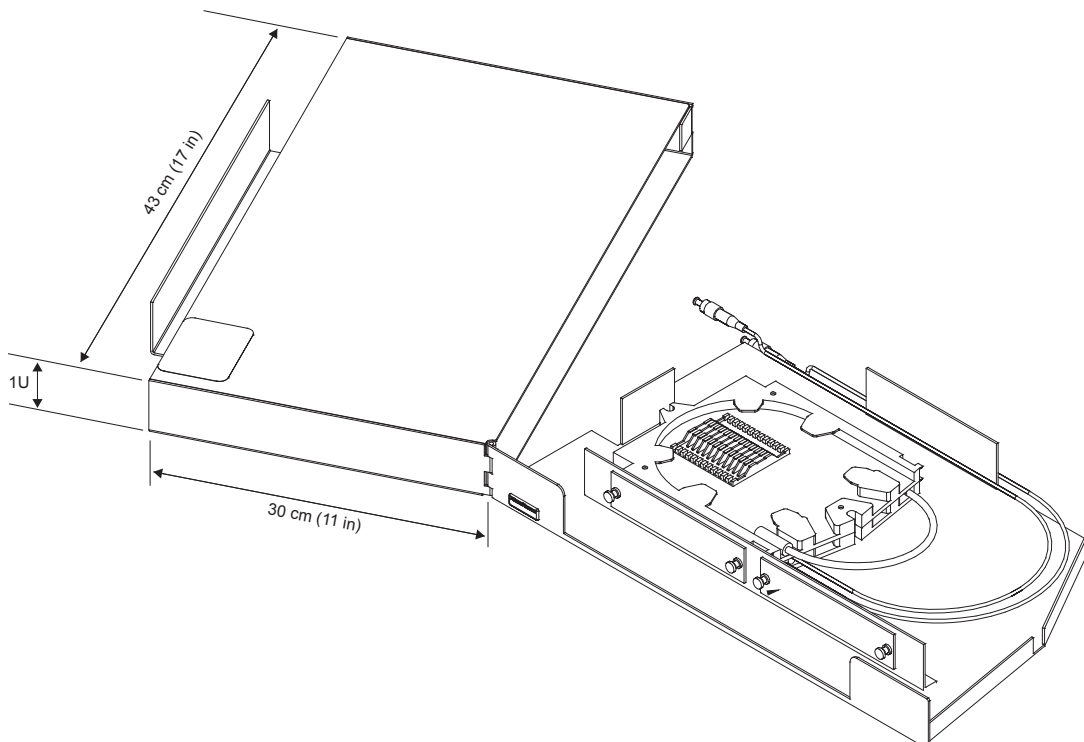

[info@senstar.com](mailto:info@senstar.com) • [senstar.com](http://senstar.com)